

RoHS
Compliant

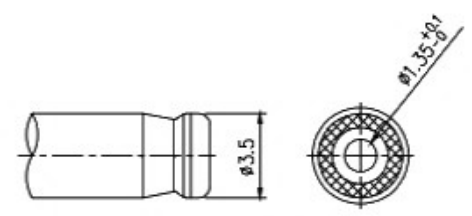
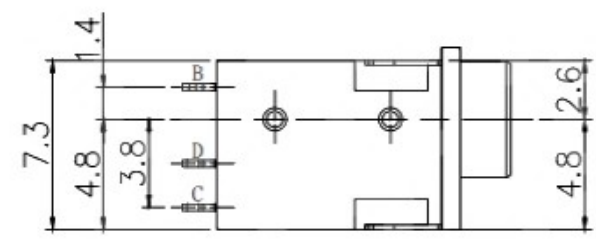
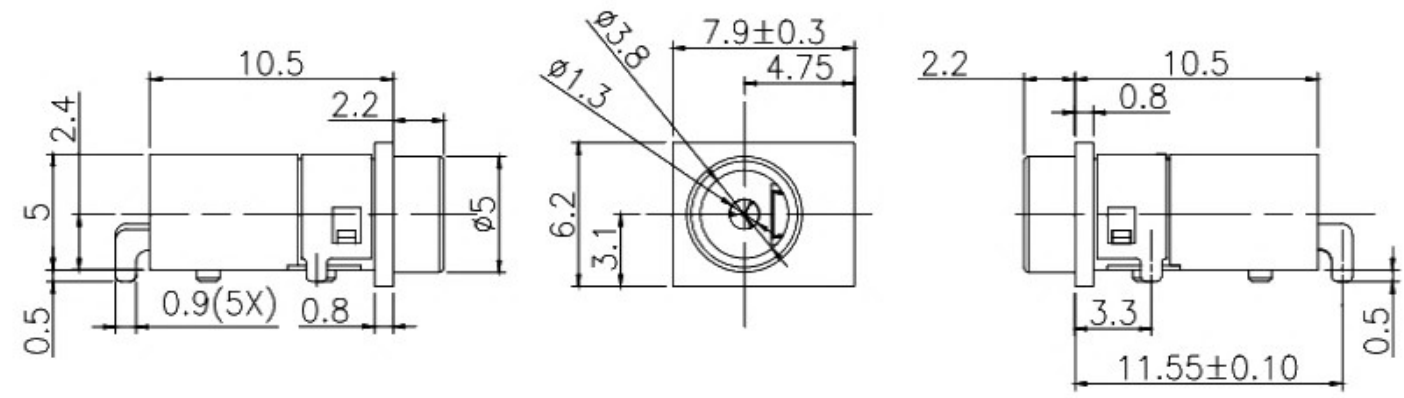

MATING PLUG $\phi 3.50$

SPECIFICATIONS

1. ELECTRICAL CHARACTERISTICS:
 - 1-1. RATING: DC 3A 12V
 - 1-2. CONTACT RESISTANCE: 30m Ω MAX(INITAL)
 - 1-3. DIELECTRIC WITHSTANDING VOL TAGE: 500V AC FOR ONE MINUTE
 - 1-4. INSULATION RESISTANCE: 100M Ω MIN, MEASURED BY 500V DC
2. MECHANICAL PERFORMANCE
 - 2.1. OPERATING FORCE :0.5-2.0kgf
3. LIFE TEST
 - 3.1.3-1. ELECTRONICS LIFE TEST 5,000 CYCLES.

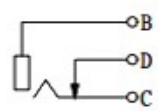

CIRCUIT

No.	DESCRIPTION	MATERIAL	PLATING
A	HOUSING	PA10T 94V0	BLACK
B	COVER	PA10T 94V0	BLACK
C	SPRING CONTAC(C)T	C5210	Au PLATED
D	PIN TEMRINAL(D)	C2680	Au PLATED
E	BREAK TERMRINAL(B)	C2680	Au PLATED

DONG GUAN XI BANG ELECTRONIC CO., LTD

PART NAME		DC POWER JACK		DRAWING	Winky	DWG. No.
PART NO.				CHECK	Roy	REV.
UNIT :		TOLERANCE UNLESS	X. X \pm 0.3	ANGLE	Jason	DATE
mm		OTHERWISE SPECIFIED	X. XX \pm 0.2	$\pm 2^\circ$	3:1	PAGE
			X. XXX \pm 0.1	SCALE		1 OF 1

COPYRIGHT RESERVED, PLEASE DO NOT COPY.