

RoHS Compliant

SYMBOL	REV.	REVISION	APPROVAL	DATE

SPECIFICATIONS

- ELECTRICAL CHARACTERISTICS:
 - 1-1.RATING: DC 12V 1A
 - 1-2.CONTACT RESISTANCE: 30mΩ MAX(INITAL)
 - 1-3.DIELECTRIC WITHSTANDING VOL TAGE: 500V AC FOR ONE MINUTE
 - 1-4.INSULATION RESISTANCE: 100MΩ MIN,MEASURED BY 500V DC
- MECHANICAL CHARACTERISTICS:
 - 2-1.INSERTION FORCE: 0.3-3.0KG
 - 2-2.WITHDRAWAL FORCE: 0.3KG-3.0KG
- LIFE TEST:5,000 CYCLES MIN

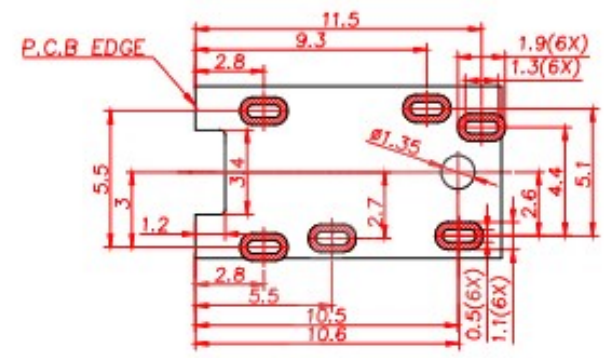
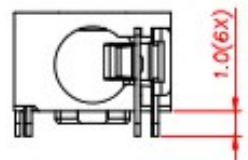
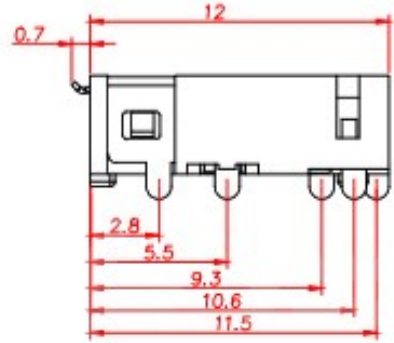
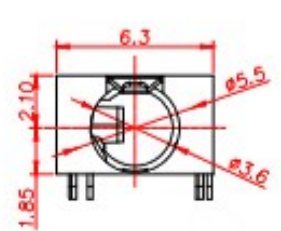
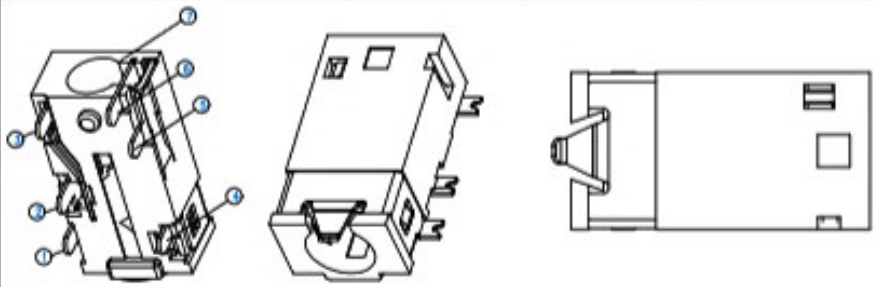

P.C.B LAYOUT TOP VIEW

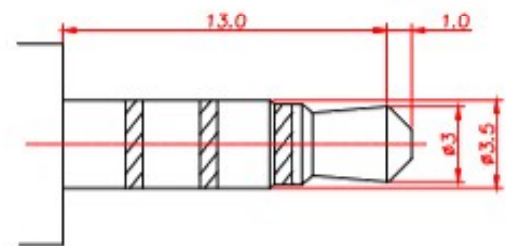
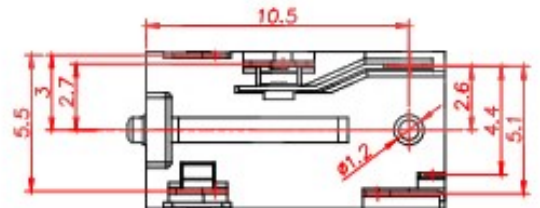

MATING PLUG

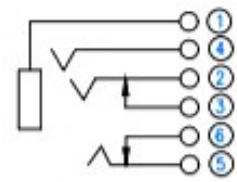

SCHEMATIC

No.	DESCRIPTION	MATERIAL	PLATING
1	TERMINAL ①	C5210	Au PLATED
2	TERMINAL ②	BeCu	Au PLATED
3	TERMINAL ③	C2680	Au PLATED
4	TERMINAL ④	C5210	Au PLATED
5	TERMINAL ⑤	C5210	Au PLATED
6	TERMINAL ⑥	C2680	Au PLATED
7	HOUSING	PPA	BLACK



COPYRIGHT RESERVED, PLEASE DO NOT COPY.

PART NAME	PHONE JACK	DRAWING	DWG. No.
PART NO.	ST-3548-PT-T10	CHECK	REV. A
UNIT :	TOLERANCE UNLESS OTHERWISE SPECIFIED	ANGLE APPROVAL	DATE 2017/07/29
III	X, X ± 0.3 X, XX ± 0.2 X, XXX ± 0.1	SCALE 5:1	PAGE 1 OF 2