

SPECIFICATION

Contact Rating: 50mA, 12V DC
 Contact Resistance: 100mΩ max
 Insulation Resistance: 100mΩ min. 500V DC
 Dielectric Strength: 250V AC/1minute
 Travel: 0.13mm
 Operating Temp: -30°C ~ +85°C
 Storage Temp: -30°C ~ +80°C

PCB MOUNTING PATTERN DIMENSION

The following soldering patterns are recommended for reflow soldering

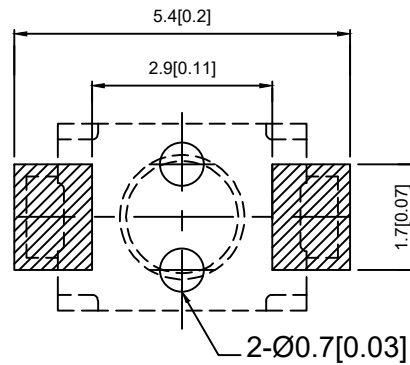
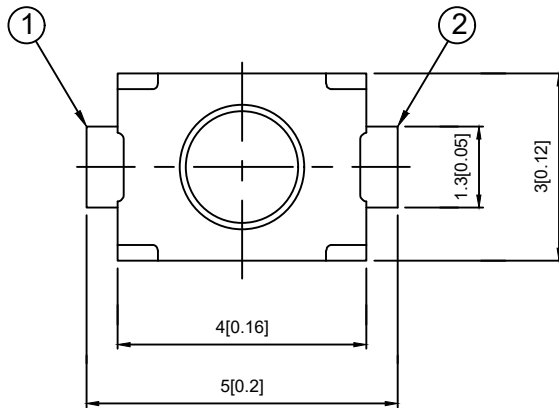

PAPT NO	TS-1185-X-X-X-A
Operating Force	A:100gf B:160gf C:260gf
Height	H:A:2.0 B:2.5
Fixed column	A:With B:Without
Keystake	A:PA46 B:Silica gel

CIRCUIT DIAGRAM

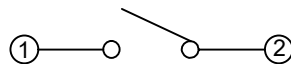

⑤	Terminal	—	2	Brass (0.30t)	Plating silvering	—
④	Contact	—	1	F.ag/Sus	Natural	—
③	Base	—	1	LCP		—
②	Cover	—	1	Brass	Plating Nickel	—
①	Keystake	—	1	LCP		—
ITEM	PAPT NAMF	TER,NO	QTY	MATERIAL	FINISHING	REMARK

DSND		DATE		SCALE: N/A	MODEL TYPE: TACT SWITCH
DWN		DATE		VIEW:	PART NO.:
CHKD		DATE		UNIT: mm/in	DWG NO.:
APPD		DATE		SIZE: A4	TS-1185-X-X-X-A
UNSPECIFIED TOLERANCES				DONG GUAN XI BANG ELECTRONIC CO., LTD	WEIGHT 1.0g
					SHEET 1/1
					REVISION A0

Δx					units: mm
Δx					tolerance: X.X ±0.2mm
Δx					X.XX ±0.1mm
MARK	DESCRIPTION	DATE	REVISED	APPROVED	X.XXX ±0.05mm
REVISIONS					
www.alpsr.com www.gdxjdz.com www.xbswitch.com					