

PCB LATOUT
TOP VIEW

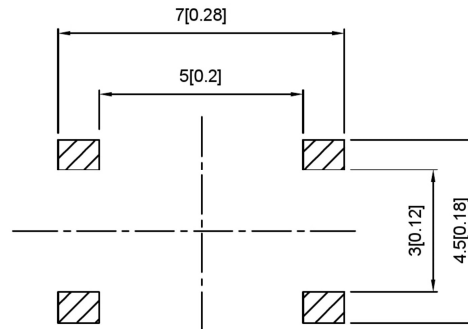

Code-x	H
A	1.5
B	1.6
C	1.7
D	2.0
E	2.5
F	3.0
G	3.5
H	4.0
I	4.5
J	5.0

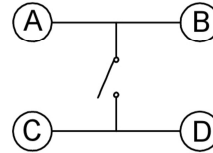
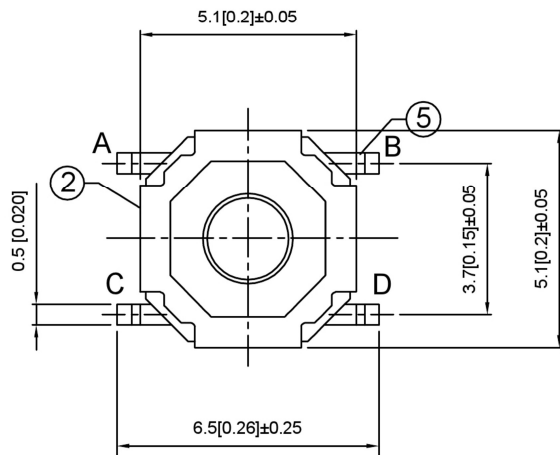

PAPT NO	TS-1187A-X-X-X
Operating Force	A:100gf B:160gf C:260gf
Height	Code-x
Fixed column	A:PA46 B:Brass

SPECIFICATION

Contact Rating: 50mA, 12V DC
 Contact Resistance: 100mΩ max
 Insulation Resistance: 100mΩ min.500V DC
 Dielectric Strength: 250V AC/1minute
 Travel: 0.25mm
 Operating Temp: -30°C~+85°C
 Storage Temp: -30°C~+80°C

⑤	Terminal	—	4	Brass (0.30t)	Plating silvering	—
④	Contact	—	1	F.ag/Sus	Natural	—
③	Base	—	1	Lcp		—
②	Cover	—	1	Sus	Plating Nickel	—
①	Keystake	—	1	Pa46/Brass		—
ITEM	PAPT NAMF	TER.NO	QTY	MATERIAL	FINISHING	REMARK

DSND		DATE		SCALE: N/A	MODEL TYPE: TACT SWITCH
DWN		DATE		VIEW:	PART NO.:
CHKD		DATE		UNIT: mm/in	DWG NO
APPD		DATE		SIZE: A4	TS-1187A-X-X-X
DONG GUAN XI BANG ELECTRONIC CO., LTD					WEIGHT 1.0g
					SHEET 1/1
					REVISION A0

MARK	DESCRIPTION	DATE	REVISED	APPROVED	units: mm	tolerance:
ΔX					X.X	±0.2mm
ΔX					X.XX	±0.1mm
ΔX					X.XXX	±0.05mm
REVISIONS					UNSPECIFIED TOLERANCES	
www.alpsr.com www.gdxjdz.com www.xbswitch.com						