

technical parameter

1. Action temperature: - 25 ~ + 85 °C
2. Rated load: DC 12V 50mA
3. Contact resistance: ≤ 50m Ω
4. Insulation resistance: ≥ 100m Ω
5. Withstand voltage: AC250V (50 Hz) / min
6. Service life: 80000 times

A	13.85	15.0	∅3.0
B	11.85	13.0	∅3.0
C	8.35	9.5	∅3.1
D	7.85	9.0	∅3.2
E	7.35	8.5	∅3.2
F	6.35	7.5	∅3.3
G	5.35	6.5	∅3.3
H	4.85	6.0	∅3.3
I	3.85	5.0	∅3.5
J	3.15	4.3	∅3.5
	L (mm)	H (mm)	A (mm)

PART NO	TC-53HF-X-X
Operating Force	C:260gf
Height	H

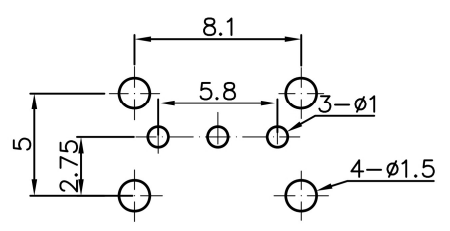

PCB board installation drawing (± 0.1)

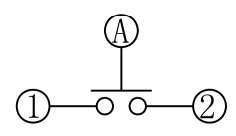
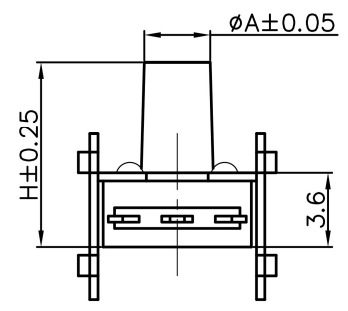

Circuit diagram

5	Contact foot	Brass t = 0.3	Plate with silver	1	
4	Pedestal	PPA black		1	
3	Reed	Composite silver		1	
2	Bracket	Cold rolled steel strip	Copper tin	1	
1	Button	PPA black		1	
	Part name	Specifications	Surface treatment	QTY	Remarks

		0~3	±0.05	±0.10	±0.20
△ X		>3~6	±0.05	±0.10	±0.30
△ X		>6~30	±0.10	±0.20	±0.50
△ X		>30~120	±0.15	±0.30	±0.80
MARK		角度		±1°	
REVISIONS					
www.alpsr.com www.gdxjdz.com www.xbswitch.com					

DSND		DATE		SCALE: N/A	MODEL TYPE: TC-53HF-X-X	
DWN		DATE		VIEW:	PART NO.:	
CHKD		DATE		UNIT: mm	DWG NO.:	
APPD		DATE		SIZE: A4		
DONG GUAN XI BANG ELECTRONIC CO., LTD				WEIGHT	SHEET	REVISION
				1.0g	1/1	A0