

— 触发角度 —

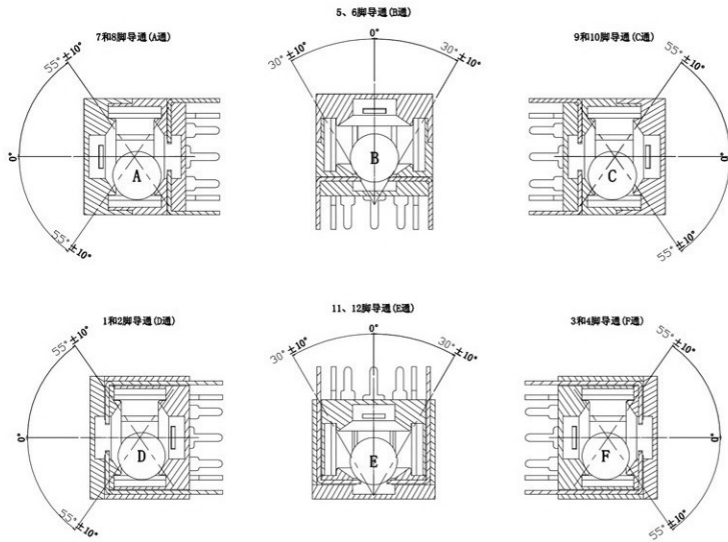

Unit=mm

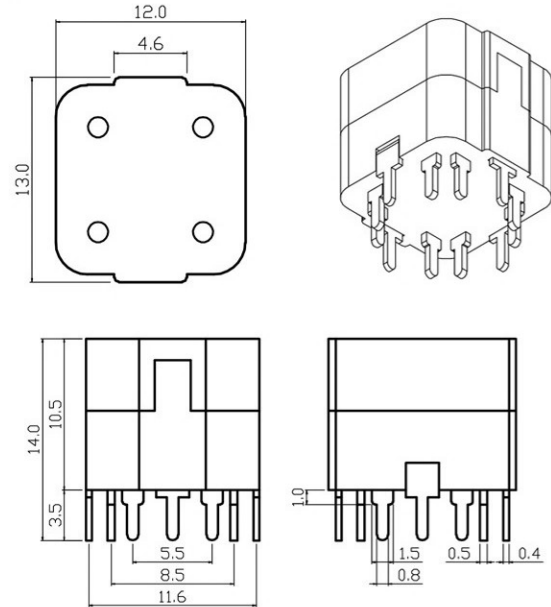

— 焊接特性 —

- 01 手工焊: : 320°C±10°C, 2-3s.
- 02 波峰焊接 : 260±10度, < 5秒
- 03 焊锡: 含锡量100%
- 04 不可使用强酸、碱性助焊剂.

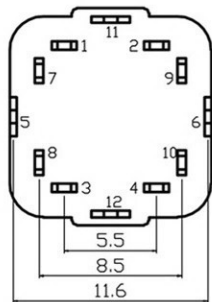

PCB Hole Layout

1DSND		DATE		SCALE: N/A	MODEL TYPE: Vibration switch
DWN		DATE		VIEW:	PART NO.:
CHKD		DATE		UNIT: mm/in	DWG NO.:
APPD		DATE		SIZE: A4	
				WEIGHT	SHEET
				1.0g	1/1
				REVISION	A0

MARK	DESCRIPTION	DATE	REVISED	APPROVED	UNSPECIFIED TOLERANCES
ΔX					units: mm
ΔX					tolerance: X.X ±0.2mm
ΔX					X.XX ±0.1mm
MARK					X.XXX ±0.05mm
REVISIONS					UNSPECIFIED TOLERANCES