

PCB Layout(Pattern side)

NOTE:
 Rating: DC 30V 0.1A
 Operating Force: 30±10gf
 Lifetime: 50,000 Cycles

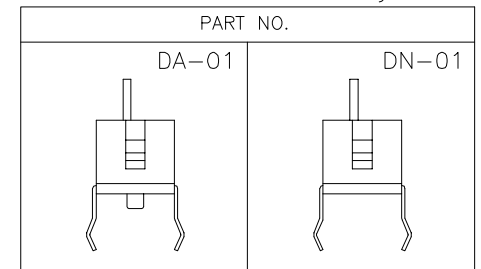
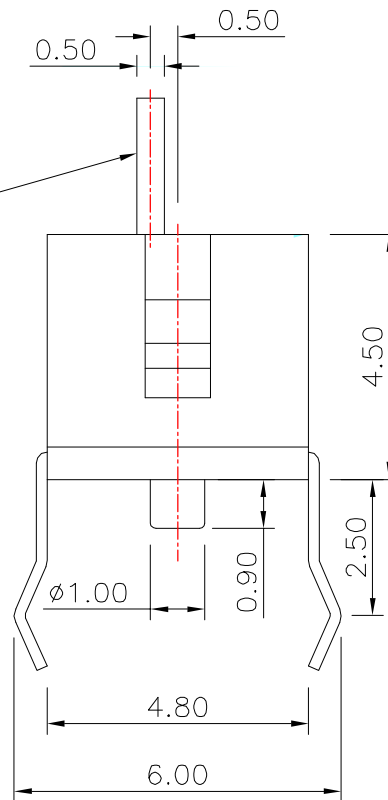
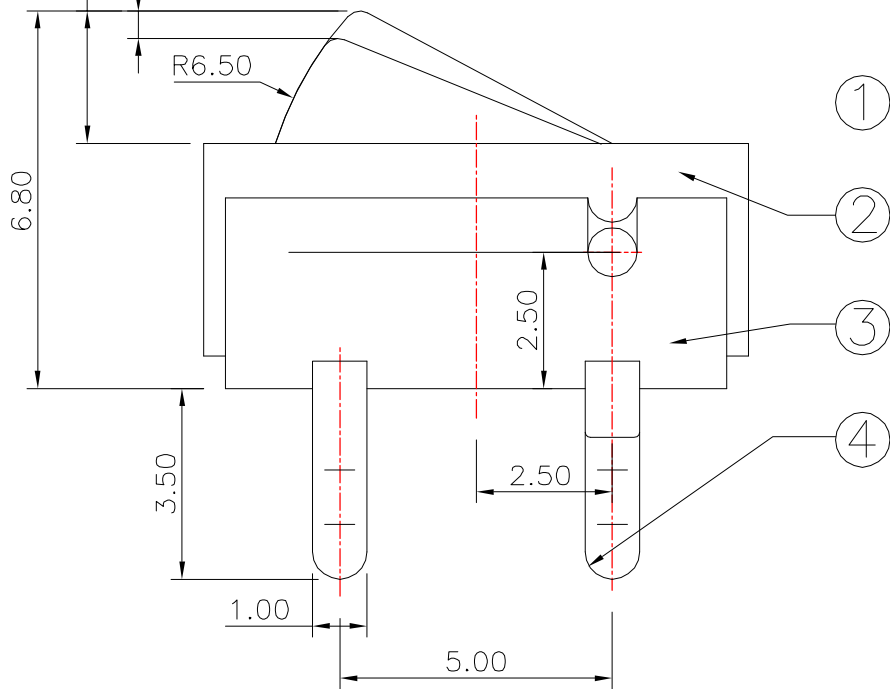

ITEM	PART NAME	TER'NO.	QTY.	MATERIAL	FINISHING	REMARK
⑤	Contact Spring	—	1	Be Alloy	Ag Plated	—
④	Terminal	—	4	Brass	Ag Plated	—
③	Housing	—	1	PA46	Black	—
②	Cover	—	1	POM	Black	—
①	Slider	—	1	POM	White	—

APPROVALS		DATE		东莞市溪榜电子有限公司 DONG GUAN XI BANG ELECTRONICS CO., LTD.		
DRAWN		2015.08.18		TITLE: DETECTOR SWITCHES		
CHECKED		2015.08.18		PART NO.		
APPROVALS		2015.08.18		UNIT: mm SCALE: 1:1 PROJ:		
TOLERANCES ARE		30~以上 ±0.30	ANGLE	DRAWING NO.		SHEET 1 OF 1
		10~30 ±0.20				
		5~10 ±0.15				
		~ 5 ±0.10				

ECN NO.	REV.	DATE.	DESCRIPTION.	CHANGE.	CHECK.	APPRO.
—	A	—	NEW	—	—	—